

# MASPERO ELEVATORI

**MASPERO ELEVATORI S.P.A.** Viale dello Sport - 22070 Appiano Gentile (CO) Italy  
Tel +39 031 3531.211 Fax +39 031 3531.255

[www.maspero.com](http://www.maspero.com)

e-mail: [comm@maspero.com](mailto:comm@maspero.com) (export dept.)

e-mail: [comm1@maspero.com](mailto:comm1@maspero.com) (vendite italia)

ASCENSORI VERTICALI E SCALE MOBILI  
VERTICAL LIFTS AND ESCALATORS



**MASPERO ELEVATORI**



*Sede di Appiano Gentile*

*Appiano Gentile Headquarters*



Fondata nel 1966 da Libero Maspero, ed oggi conosciuta in tutto il mondo quale leader nella produzione di impianti ascensori speciali, Maspero Elevatori offre ad ogni committente, sia pubblico che privato, la più ampia possibilità di personalizzazione oggi disponibile sul mercato.

Oltre agli esclusivi ascensori inclinati, la produzione di Maspero include ascensori panoramici delle più svariate forme e finiture, prodotti anche su disegno, eventualmente con pareti, tetto, pavimento e porte in cristallo.

Il rispetto dei più recenti standard europei ed internazionali e del regime di qualità ISO 9001 garantiscono la prestazione di ogni impianto, assicurando all'edificio in cui è stato installato un valore aggiunto di esclusività e funzionalità.

Maspero Elevatori ha inoltre brevettato il sistema Koala®, realizzabile anche in impianti vetrati, che non necessita di locale macchina: un brevetto rivoluzionario che consente un notevole contenimento dei costi accessori.

Maspero Elevatori è dotata di certificazione SOA e Vision, ed è qualificata secondo l'Allegato XIII della Direttiva Ascensori, oltre che per la progettazione di impianti antideflagranti classificati Eexd ed Atex.

*Established in 1966 by Libero Maspero and now world-known as leader in special lifts, Maspero Elevatori grants each Customer, both public or private, the widest available range of custom-made products.*

*Besides exclusive inclined lifts, Maspero production range includes scenic lifts in many shapes and finishes, even tailored on the Customer's sketches or glazed with walls, flooring, ceilings, and doors in safety glass.*

*The respect of the latest european and international standards and of our internal ISO 9001 procedure guarantees each single lift's reliable performance, improving every building's style and good functionality.*

*Finally, Maspero Elevatori patented the Koala ® system, a roped lift without machine room, even panoramic, which allows a significant reduction of additional costs.*

*Maspero Elevatori is provided with SOA and Vision certifications, and is certified according to Annex XIII of the Lift Directive, as well as for the design of explosion-proof elevators Eexd and Atex rated.*

**IMPIANTO A FUNE SENZA LOCALE MACCHINA KOALA®**

Portata 570 kg

2 Fermate adiacenti

Velocità 1.0 m/s

Manovra universale a pulsanti con controllo remoto



**KOALA® ROPED MACHINE ROOM-LESS LIFT**

Rated load 570 kg

No. 2 adjacent stops

Rated speed 1.0 m/s

Single automatic push button with remote control

**QUARTIERE DELLA MODA - MILANO**

Impianto a fune con locale macchina inferiore

Portata 320 kg

5 Fermate in linea

Velocità 1.0 m/s

Manovra simplex a prenotazione



**MILAN - FASHION DISTRICT**

*Roped lift with lower machine room*

*Rated load 320 kg*

*No. 5 stops in line*

*Rated speed 1.0 m/s*

*Simplex collective operation*



**BATTERIA DI DUE ASCENSORI A FUNE**

Portata 850 kg

9 Fermate opposte

Velocità 1.6 m/s V.V.V.F.

Manovra duplex a prenotazione



**NO.2 DUPLEX ROPED ELEVATORS**

*Rated load 850 kg*

*No. 9 opposite stops*

*Rated speed 1.6 m/s V.V.V.F.*

*Duplex collective operation*

**ASCENSORE IDRAULICO**

Portata 400 kg

3 Fermate in linea

Velocità 0.6 m/s

Manovra universale a pulsanti



**HYDRAULIC LIFT**

Rated load 400 kg

No. 3 stops in line

Rated speed 0.6 m/s

Single automatic push button



**BATTERIA DI TRE ASCENSORI A FUNE**

Portata 850 kg

7 Fermate in linea

Velocità 1.6 m/s V.V.V.F.

Manovra triplex a prenotazione



**NO.3 TRIPLEX ROPED ELEVATORS**

*Rated load 850 kg*

*No. 7 stops in line*

*Rated speed 1.6 m/s V.V.V.F.*

*Triplex collective operation*

**BATTERIA DI DUE ASCENSORI IDRAULICI**

Portata 400 kg

4 Fermate in linea

Velocità 0,8 m/s

Manovra duplex a prenotazione



**NO.2 HYDRAULIC DUPLEX ELEVATORS**

Rated load 400 kg

No. 4 stops in line

Rated speed 0,8 m/s

Duplex collective operation

QUARTIERE DELLA MODA - MILANO

BATTERIA DI DUE IMPIANTI IDRAULICI CON PISTONE CENTRALE

Portata 840 kg

4 Fermate in linea

Velocità 0.6 m/s

Manovra simplex a prenotazione



**MILAN - FASHION DISTRICT**  
**NO. 2 HYDRAULIC LIFTS WITH CENTRAL RAM**  
Rated load 840 kg  
No. 4 stops in line  
Rated speed 0.6 m/s  
Simplex collective operation



**NO.2 IMPIANTI IDRAULICI**

Portata 860 kg

4 Fermate in linea

Velocità 1 m/s

Manovra duplex a prenotazione



**NO.2 DUPLEX HYDRAULIC LIFT**

Rated load 860 kg

No. 4 stops in line

Rated speed 1.0 m/s

Duplex collective operation

**BATTERIA DI DUE ASCENSORI A FUNE**

Portata 630 kg

7 Fermate in linea

Velocità 1.2 m/s

Manovra duplex a prenotazione



**NO.2 ROPED DUPLEX LIFTS**  
Rated load 630 kg  
No. 7 stops in line  
Rated speed 1.2 m/s  
Duplex collective operation

**BATTERIA DI DUE ASCENSORI A FUNE**

Portata 630 kg

7 Fermate in linea

Velocità 1.5 m/s

Manovra simplex a prenotazione



**NO.2 ROPED DUPLEX LIFTS**

*Rated load 630 kg*

*No. 7 stops in line*

*Rated speed 1.5 m/s*

*Simplex collective operation*



**ASCENSORI A FUNI IN VANO SCALA**

Portata 300 kg

7 Fermate in linea

Velocità 1.0 m/s

Manovra universale a pulsanti



**ROPED LIFT IN STAIRWAY**

*Rated load 300 kg*

*No. 7 stops in line*

*Rated speed 1.0 m/s*

*Single automatic push button*

**MONTA - AUTO OLEODINAMICO**

Portata 2500 kg

3 Fermate opposte

Velocità 0.3 m/s

Manovra universale a pulsanti



**HYDRAULIC CAR LIFTS**  
Rated load 2500 kg  
No. 3 opposite stops  
Rated speed 0.3 m/s  
Single automatic push button

**IMPIANTO IDRAULICO CON LOCALE MACCHINA**

Portata 1750 kg

2 Fermate in linea

Velocità 0,6 m/s

Manovra universale a pulsanti



**HYDRAULIC LIFT WITH MACHINE ROOM**

Rated load 1750 kg

No.2 stops in line

Rated speed 0.6 m/s

Single automatic push button

**No. 2 MONTALETTIGHE ELETTRICI**

Portata 1300 kg

8 Fermate opposte

Velocità 1.2 m/s

Manovra collettiva duplex con modalità antincendio



**No. 2 ROPED BED LIFTS**

Rated load 1300 kg

No. 8 opposite stops

Rated speed 1.2 m/s

Duplex collective operation with firefighters mode



**NO. 2 SCALE MOBILI AD USO COMMERCIALE**

Larghezza gradino 800 mm  
Velocità 0,5 m/s  
Portata 6.750 passeggeri/h



**NO.2 ESCALATORS IN COMMERCIAL SERVICE**

Step width 800 mm  
Rated speed 0.5 m/s  
Rated flow 6.750 p/h

**PONTEPORIA - PORTO DI GENOVA**

No. 2 scale mobili in servizio pubblico

Corsa 16 m

Larghezza gradino 900 mm

Angolo di inclinazione 30°



**GENOA PORT**

No. 2 escalators in public service

Travel 16 m

Step width 900 mm

Angle 30°



**ASCENSORE ELETTRICO**

Manovra collettiva selettiva salita/discesa

Portata 1000 kg

Velocità 1 m/s V.V.V.F.

Fermate 7/Accessi 7

Cabina in cristallo e ottone



***ELECTRIC LIFT***

*Collective selective up and down operation*

*Rated load 1000 kg*

*Speed 1 m/s*

*No. 7 stops*

*No. 7 entrances*

*Car finished in glass and brass*

**ASCENSORI ELETTRICI A NORME EN81.1**  
**ELECTRIC LIFTS ACCORDING TO EN81.1**

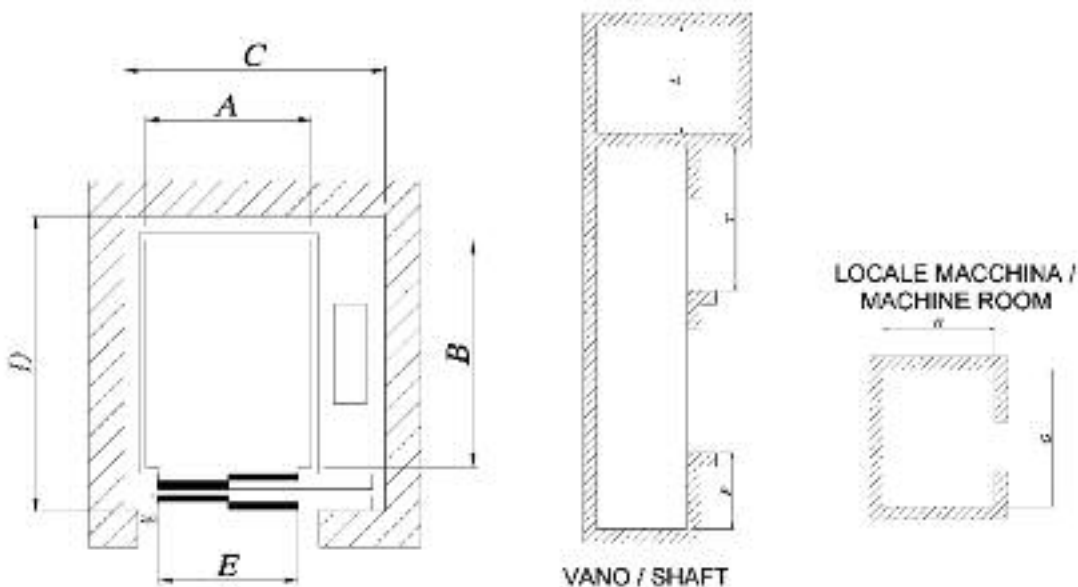

Portata / Rated load \_\_\_\_\_ kg  
 Persone / passengers \_\_\_\_\_  
 Velocità / speed \_\_\_\_\_ m/sec  
 Corsa / total travel \_\_\_\_\_ m  
 Fermate / stop \_\_\_\_\_

PORTATA / RATED LOAD		kg	350	450	600	850	1350	1600	
PERSONE / PASSENGERS		N°	4	6	8	11	16	21	
CABINA / CAR	LARGHEZZA / WIDTH	A mm	800	950	1100	1370	1370	1500	
	PROFONDITA' / DEPTH	B mm	1200	1300	1400	1500	2200	2200	
VANO / SHAFT	LARGHEZZA / WIDTH	C mm	1500	1650	1850	1950	2150	2300	
	PROFONDITA' / DEPTH	D mm	1600	1700	1750	2200	2650	2650	
PORTE / DOORS		E mm	750	800	800	900	1000	1000	
FOSSA / PIT	PROFONDITA' / DEPTH	F mm					1500	1600	
	Velocità / speed ≤ 0,63 m/s						1500	1600	
	Velocità / speed ≤ 1,00 m/s						1600	1700	
TESTATA / HEADROOM T	Velocità / speed ≤ 0,63 m/s						3700	3900	
	Velocità / speed ≤ 1,00 m/s						3800	4000	
	Velocità / speed ≤ 1,50 m/s						4000	4200	
LOCALE MACCHINA / MACHINE ROOM	LARGHEZZA / WIDTH	G mm	2500	2700	3000	3200	3500		
	PROFONDITA' / DEPTH	H mm	2500	2700	3000	3500	4000		
	ALTEZZA / HEIGHT	mm							2100

ALTEZZA INTERNA CABINA / INTERNAL CAR HEIGHT 2200mm  
 ALTEZZA PORTE / DOORS HEIGHT 2000mm

MODELLI CON ALTRE PORTATE SONO DISPONIBILI / MODELS WITH OTHER RATED LOAD ARE AVAILABLE

**ASCENSORI IDRAULICI A NORME EN81.2  
HYDRAULIC LIFTS ACCORDING TO EN81.2**

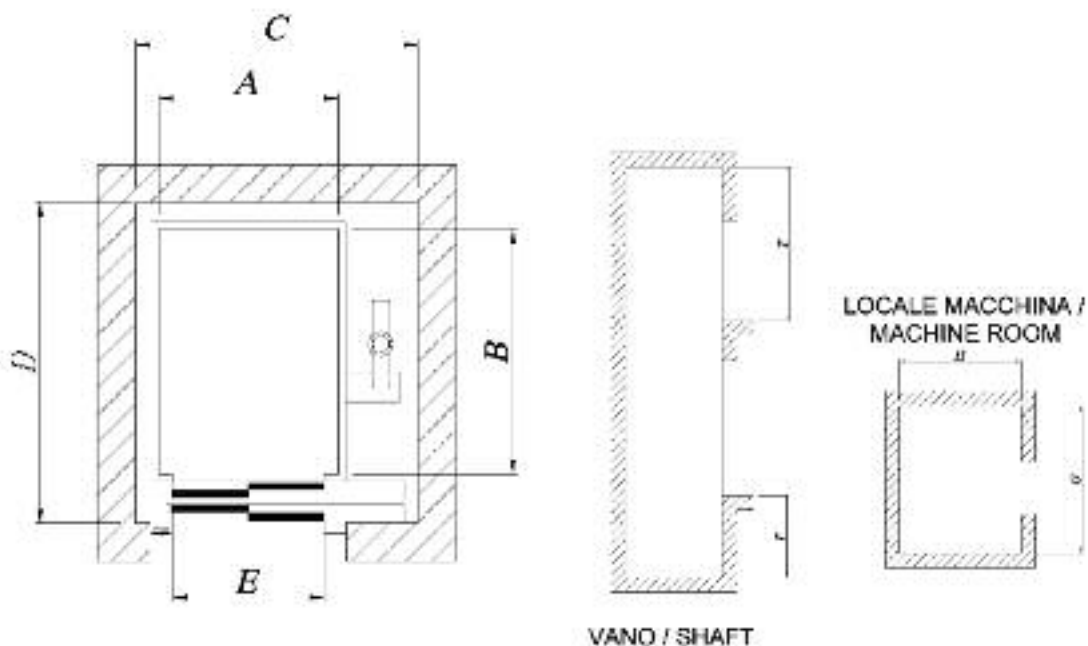

Portata / Rated load	_____	kg
Persone / passengers	_____	
Velocità / speed	_____	m/sec
Corsa / total travel	_____	m
Fermate / stop	_____	

PORTATA / RATED LOAD	kg	350	450	600	850	1350	1600	
PERSONE / PASSENGERS	N°	4	6	8	11	16	21	
CABINA / CAR	LARGHEZZA / WIDTH	A mm	800	950	1100	1370	1500	
	PROFONDITA' / DEPTH	B mm	1200	1300	1400	1500	2200	
VANO / SHAFT	LARGHEZZA / WIDTH	C mm	1400	1500	1700	2000	2300	
	PROFONDITA' / DEPTH	D mm	1600	1700	1800	1900	2650	
PORTE / DOORS	E mm	750	800	800	900	1000	1000	
FOSSA / PIT	PROFONDITA' / DEPTH	F mm					1500	1600
	Velocità / speed ≤ 0,63 m/s						1650	1750
TESTATA / HEADROOM	Velocità / speed ≤ 0,63 m/s						3500	
	Velocità / speed ≤ 1,00 m/s						3500	
LOCALE MACCHINA / MACHINE ROOM	LARGHEZZA / WIDTH	G mm					2000	
	PROFONDITA' / DEPTH	H mm					1800	
	ALTEZZA / HEIGHT	mm					2100	

ALTEZZA INTERNA CABINA / INTERNAL CAR HEIGHT 2200mm  
 ALTEZZA PORTE / DOORS HEIGHT 2000mm  
 DISTANZA LOCALE MACCHINA 10 MT MAX. / MACHINE ROOM DISTANCE 10 MT. MAX.

MODELLI CON ALTRE PORTATE SONO DISPONIBILI / MODELS WITH OTHER RATED LOAD ARE AVAILABLE

MASPERO ELEVATORI



# KOALA3-A®

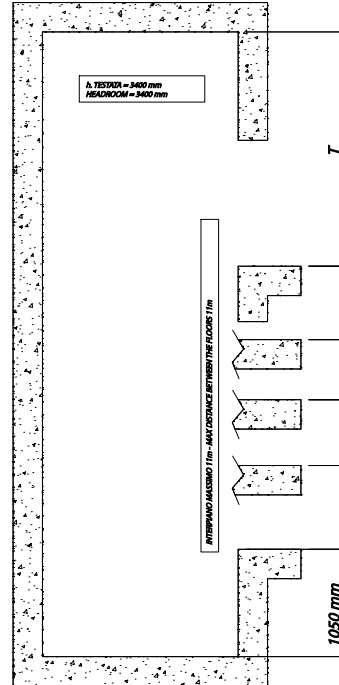
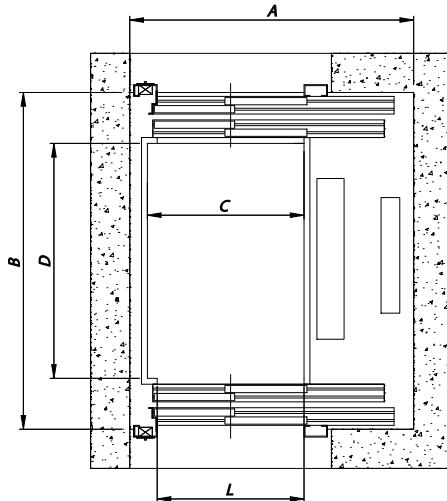

PORTATA LOAD	N. PERSONE PASSENGERS	CABINA CAR	PORTA DOOR	IANO SHAFT
Kg	N°	C X D mm	mm	A X B mm
375	5	800X1200	750	1450X1550/1720*
480	6	950X1300	800/850	1600X1650/1820*
630	8	1100X1400	800/900	1750X1750/1920*
900	12	1370X1500	900/1000	2050X1850/2030*

\*INFORMAZIONE: IANO CON CABINA DOPPIO ACCESSO - SHUTTLE DISPONIBILE SU AMBUE LE PARTI OPPOSITE  
 \*ALTEZZA INTERNO CABINA 2200 mm - CAR INTERNAL HEIGHT 2200 mm  
 \*DISPONIBILE ANCHE CON CABINA 3 ACCESSI - AVAILABLE WITH 3 DOORS ON THREE SIDES  
 \*ELEVATOR FLOOR AD 1 m/sec - SPEED UP TO 1 m/s

MASPERO ELEVATORI



# KOALA3-B®

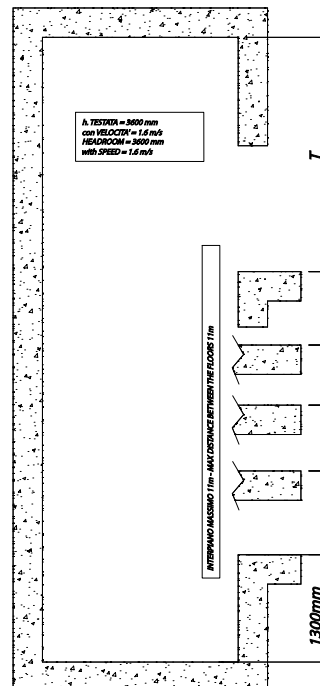
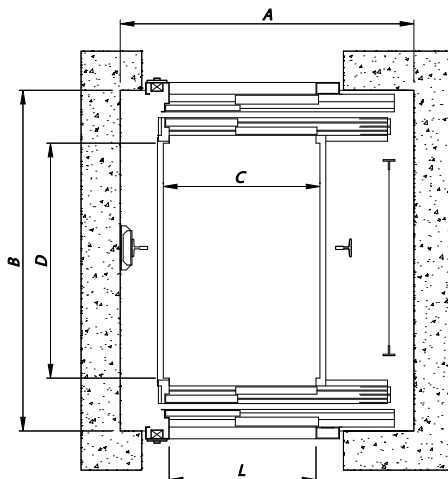

PORTATA LOAD	PERSONE PASSENGERS	CABINA CAR	PORTA DOOR	IANO SHAFT
Kg	N°	C X D mm	mm	A X B mm
480	6	950X1300	800/850	1650X1650/1850*
630	8	1100X1400	800/900	1800X1750/1950*
900	12	1400X1500	900/1000	2100X1850/2050*
1000	13	1100x2100	900/1000	1850X2450/2650*
1200	16	1250X2200	1000/1100	2000X2550/2750*
1600	21	1400X2400	1100/1300	2300X2750/2950*

\*INFORMAZIONE: IANO CON CABINA DOPPIO ACCESSO - SHUTTLE DISPONIBILE SU AMBUE LE PARTI OPPOSITE  
 \*ALTEZZA INTERNO CABINA 2200 mm - CAR INTERNAL HEIGHT 2200 mm  
 \*DISPONIBILE ANCHE CON PORTATE E VELOCITA' SUPERIORI - CONVERSIONE LA HOCHTIRI RETE DI VENDITA  
 \*AVAILABLE HIGHER RATED LOADS AND SPEED - PLEASE CONTACT OUR SALES AGENTS

